

5-Phase Stepping Motor and Driver Package CSK Series

Introduction

Motor & Driver Packages

2-Phase Stepping Motors

Controllers

Low-Speed Synchronous Motors

Accessories

Before Using a Stepping Motor

AS	AS PLUS	ASC	RK	CRK II	CSK	PMC	UMK	CSK	PK/PV	PK	UI2120G	EMP401	EMP402	SG8030J	SMK
AC Input	DC Input	DC Input	AC Input	DC Input	DC Input	AC Input	DC Input	DC Input	without Encoder	with Encoder	with Indexer				
Closed Loop <i>Q572P</i>			5-Phase Microstep		5-Phase Full/Half		2-Phase Full/Half								

Additional Information

Technical ReferenceF-1
 General InformationG-1

5-Phase Stepping Motor and Driver Package

CSK Series

The **CSK** Series combines a 5-phase stepping motor and a 24 VDC input board-level driver to provide high torque, high resolution and low vibration in a compact package.



Features

● High torque

The **CSK** Series features **PK** motors, designed to produce high torque in a compact frame size.

● Low Vibration

Smooth rotation is achieved with no noticeable resonance, allowing for low vibration and low noise.

● Compact Package

Both the motor and driver are compact in design, making them perfect for reducing the size and weight of any system.

● High Resolution

5-phase stepping motors move 0.72° per step in full-step mode and 0.36° per step in half-step mode —2.5 times the resolution of a 2-phase stepping motor. This mechanically reduced step angle makes for extremely accurate positioning.

● Tapered Hobbed (TH) Geared Type

These low backlash geared stepping motors provide high permissible torque in a compact size. They are optimal for applications in which high torque is required in tight spaces.

Safety Standards and CE Marking

Product	Standards	Certification Body	File No.	CE Marking
Stepping Motor	UL1004, UL519 CSA C22.2 No.77 CSA C22.2 No.100	UL	E64199	EMC Directives
	UL508C CSA C22.2 No.14			
Driver	UL1950 CSA C22.2 No.950	UL	E208200	

- Approval conditions for UL1950: Class III equipment, SELV circuit, Pollution degree 2
- **CSK54**□ [Motor frame size: 1.65 in. sq (42 mm sq.)] types do not comply with CSA standards.
- **CSK59**□ [Motor frame size: 3.35 in. sq (85 mm sq.)] type is not recognized by UL and CSA.
- When the system is approved under various safety standards, the model names on the motor and driver nameplates are the approved model names.
- **List of Motor and Driver Combinations** → Page C-134
- **Details of Safety Standards** → Page G-2
- The EMC value changes according to the wiring and layout. Therefore, the final EMC level must be checked with the motor/driver incorporated in the user's equipment.

System Configuration

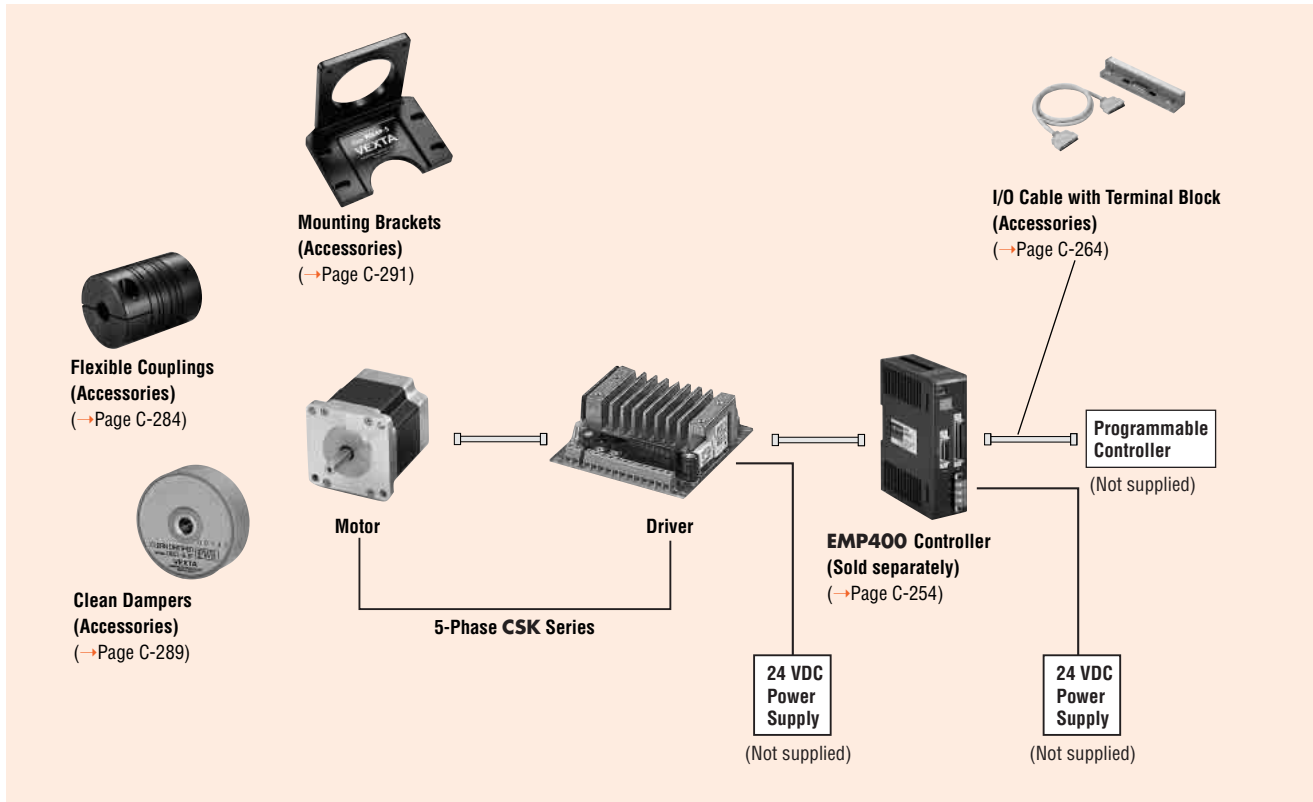

An example of a single-axis system configuration with the **EMP400** Series controller.

Product Number Code

Standard Type

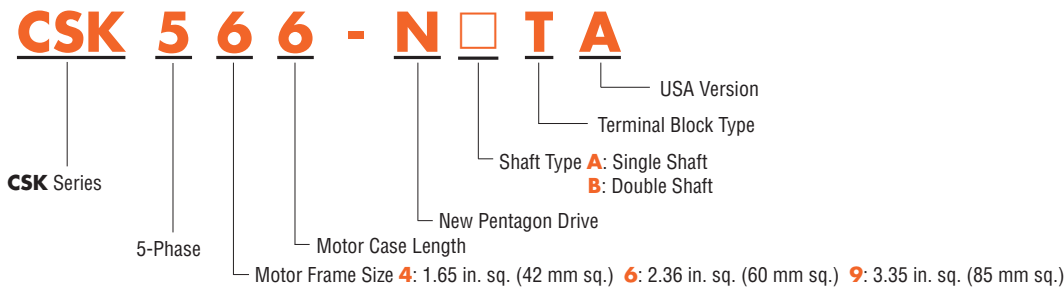

TH Geared Type

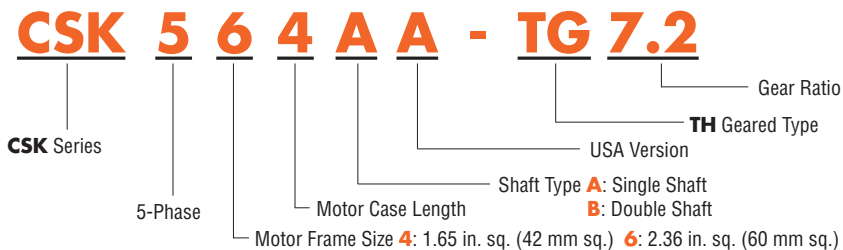

Product Line

Type	Power Supply Voltage	Maximum Holding Torque		
		□ 1.65 in. (42 mm)	□ 2.36 in. (60 mm)	□ 3.35 in. (85 mm)
Standard Type	24 VDC	18.4~34 oz-in (0.13~0.24 N-m)	59~230 oz-in (0.42~1.66 N-m)	290~890 oz-in (2.1~6.3 N-m)
TH Geared Type		3~13.2 lb-in (0.35~1.5 N-m)	11~35 lb-in (1.25~4 N-m)	—

Standard Type

Motor Frame Size: 1.65 in. (42 mm), 2.36 in. (60 mm)



Specifications

Model	Single Shaft	CSK543-NATA	CSK544-NATA	CSK545-NATA	CSK564-NATA	CSK566-NATA	CSK569-NATA
	Double Shaft	CSK543-NBTA	CSK544-NBTA	CSK545-NBTA	CSK564-NBTA	CSK566-NBTA	CSK569-NBTA
Maximum Holding Torque	oz-in (N·m)	18.4 (0.13)	25 (0.18)	34 (0.24)	59 (0.42)	117 (0.83)	230 (1.66)
Rotor Inertia J	oz-in ² (kg·m ²)	0.191 (35×10 ⁻⁷)	0.3 (54×10 ⁻⁷)	0.37 (68×10 ⁻⁷)	0.96 (175×10 ⁻⁷)	1.53 (280×10 ⁻⁷)	3.1 (560×10 ⁻⁷)
Rated Current	A/phase	0.75			1.4		
Basic Step Angle		0.72°					
Power Source		24 VDC±10% 1.3 A			24 VDC±10% 2.1 A		
Excitation Mode		<ul style="list-style-type: none"> ● Full Step (4 phase excitation): 0.72°/step ● Half Step (4-5 phase excitation): 0.36°/step 					
Weight	Motor lb. (kg)	0.46 (0.21)	0.59 (0.27)	0.77 (0.35)	1.3 (0.6)	1.8 (0.8)	2.9 (1.3)
	Driver lb. (kg)	0.31 (0.14)					
Dimension No.	Motor	1			2		
	Driver	6					

How to read specifications table → Page C-9

Speed — Torque Characteristics

How to Read Speed-Torque Characteristics → Page C-10

CSK543-NBTA

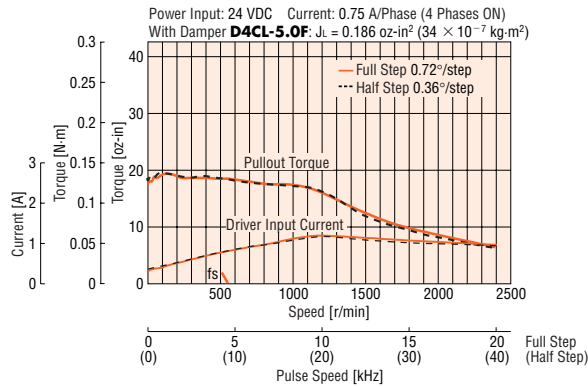

CSK564-NBTA

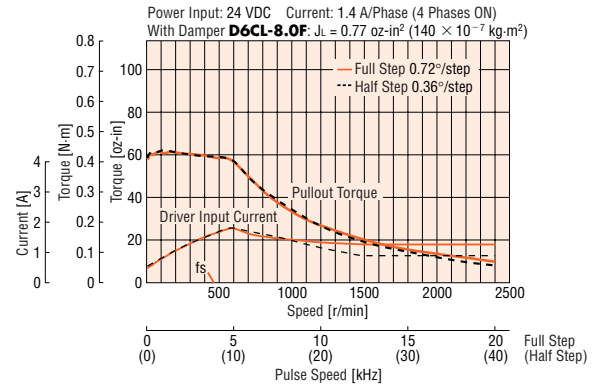

CSK544-NBTA

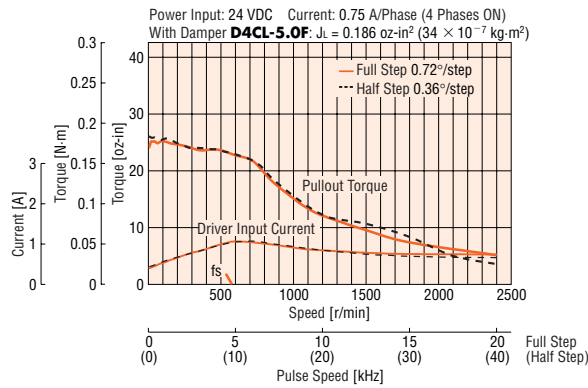

CSK566-NBTA

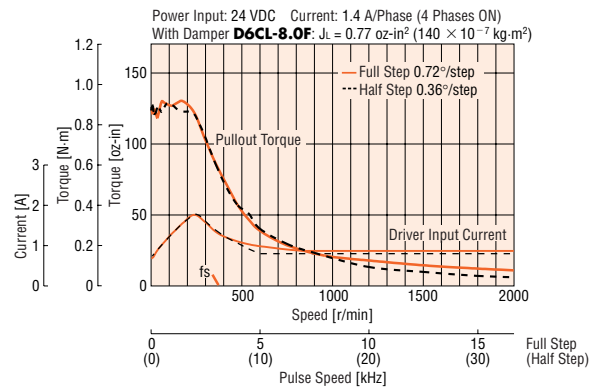

CSK545-NBTA

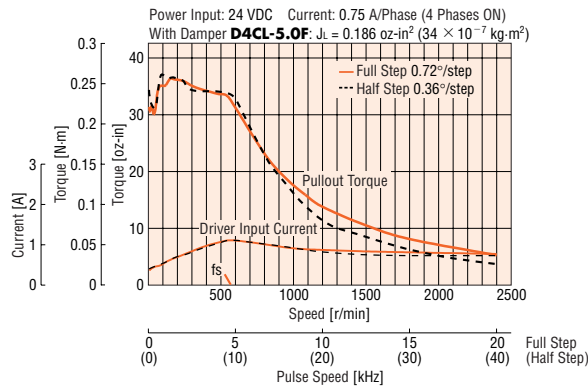

CSK569-NBTA

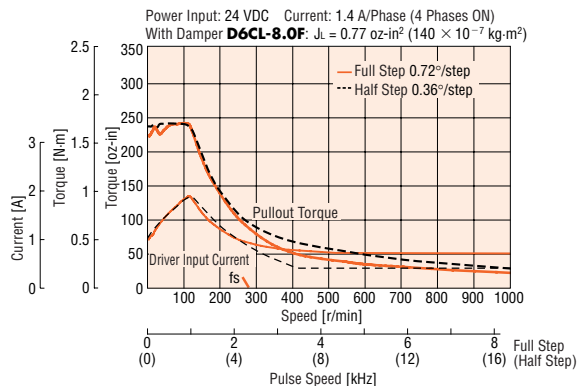

Note:

The pulse input circuit responds up to approximately 100 kHz with a pulse duty of 50%.

Standard Type

Motor Frame Size: 3.35 in. (85 mm)



Specifications

Model	Single Shaft	CSK596-NATA	CSK599-NATA	CSK5913-NATA
	Double Shaft	CSK596-NBTA	CSK599-NBTA	CSK5913-NBTA
Maximum Holding Torque	oz-in (N·m)	290 (2.1)	580 (4.1)	890 (6.3)
Rotor Inertia J	oz-in ² (kg·m ²)	7.7 (1400×10 ⁻⁷)	14.8 (2700×10 ⁻⁷)	22 (4000×10 ⁻⁷)
Rated Current	A/phase	2.8		
Basic Step Angle		0.72°		
Power Source		24 VDC±10% 4 A		
Excitation Mode		<ul style="list-style-type: none"> ● Full Step (4 phase excitation): 0.72°/step ● Half Step (4-5 phase excitation): 0.36°/step 		
Weight	Motor lb. (kg)	3.7 (1.7)	6.2 (2.8)	8.4 (3.8)
	Driver lb. (kg)	0.55 (0.25)		
Dimension No.	Motor	3		
	Driver	7		

How to read specifications table → Page C-9

Speed — Torque Characteristics

How to Read Speed-Torque Characteristics → Page C-10

CSK596-NBTA

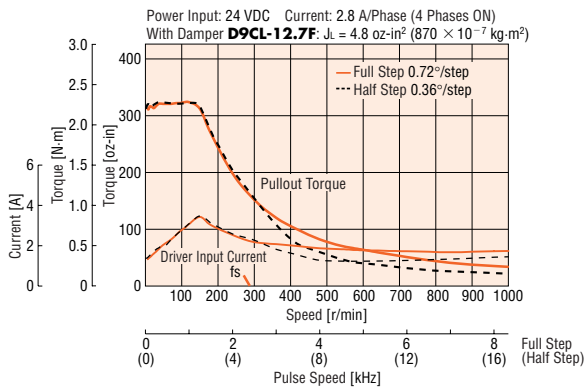

CSK599-NBTA

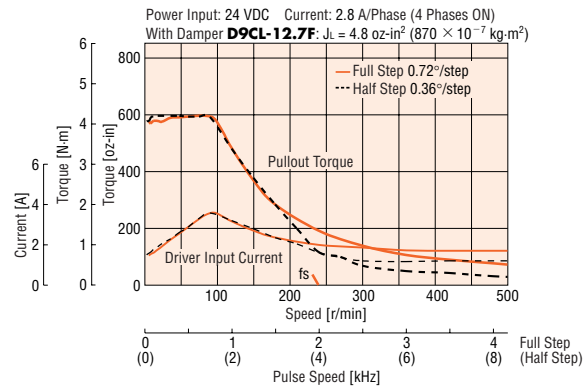

CSK5913-NBTA

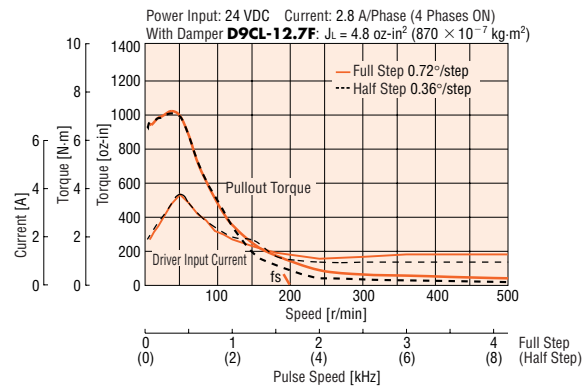

Note:

The pulse input circuit responds up to approximately 100 kHz with a pulse duty of 50%.

TH Geared Type

Motor Frame Size: □ 1.65 in. (□ 42 mm)



Specifications

Model	Single Shaft	CSK543AA-TG3.6	CSK543AA-TG7.2	CSK543AA-TG10	CSK543AA-TG20	CSK543AA-TG30
	Double Shaft	CSK543BA-TG3.6	CSK543BA-TG7.2	CSK543BA-TG10	CSK543BA-TG20	CSK543BA-TG30
Maximum Holding Torque	lb-in (N·m)	3 (0.35)	6.1 (0.7)	8.8 (1)	13.2 (1.5)	13.2 (1.5)
Rotor Inertia J	oz-in ² (kg·m ²)	0.191 (35×10 ⁻⁷)				
Rated Current	A/phase	0.75				
Basic Step Angle		0.2°	0.1°	0.072°	0.036°	0.024°
Gear Ratio		3.6:1	7.2:1	10:1	20:1	30:1
Permissible Torque	lb-in (N·m)	3 (0.35)	6.1 (0.7)	8.8 (1)	13.2 (1.5)	13.2 (1.5)
Backlash	Arc minute (degrees)	45 (0.7°)	25 (0.417°)	25 (0.417°)	15 (0.25°)	15 (0.25°)
Permissible Speed Range (Gear Output Shaft Speed)	r/min	0~500	0~250	0~180	0~90	0~60
Power Source		24 VDC±10% 1.3 A				
Excitation Mode	Full Step	0.2°/step	0.1°/step	0.072°/step	0.036°/step	0.024°/step
	Half Step	0.1°/step	0.05°/step	0.036°/step	0.018°/step	0.012°/step
Weight	Motor lb. (kg)	0.73 (0.33)				
	Driver lb. (kg)	0.31 (0.14)				
Dimension No.	Motor	4				
	Driver	6				

How to read specifications table → Page C-9

Note:

- Direction of rotation of the motor and that of the gear output shaft are the same for models with gear ratios of 3.6:1, 7.2:1 and 10:1. It is opposite for 20:1 and 30:1 gear ratios.

Speed — Torque Characteristics

How to Read Speed-Torque Characteristics → Page C-10

CSK543BA-TG3.6

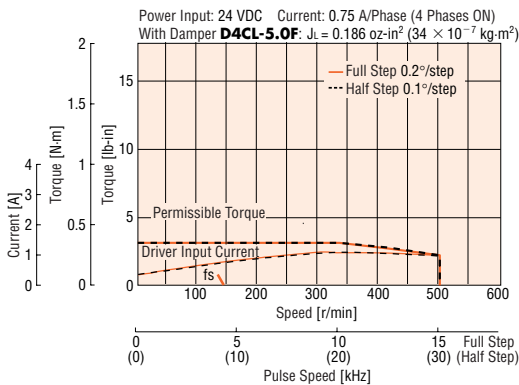

CSK543BA-TG20

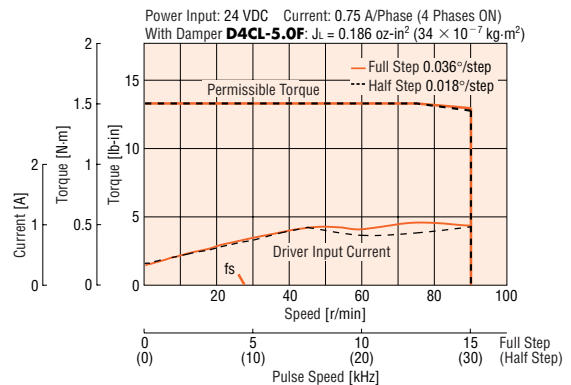

CSK543BA-TG7.2

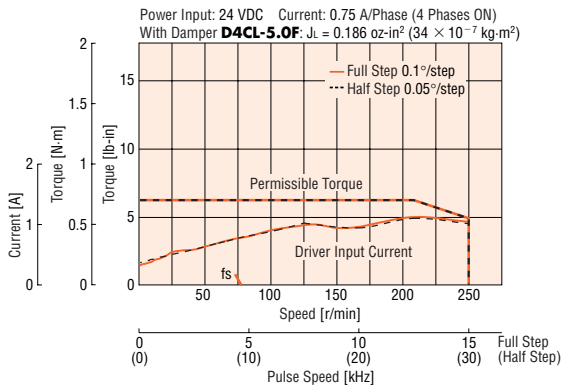

CSK543BA-TG30

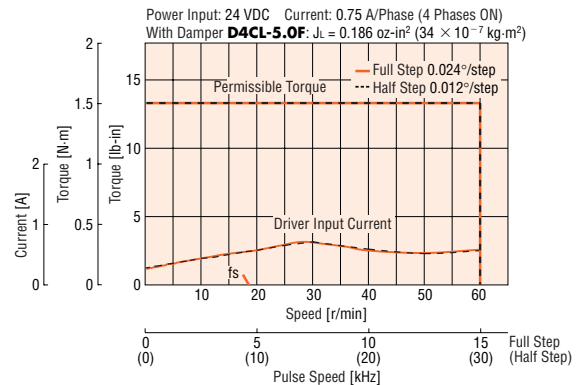

CSK543BA-TG10

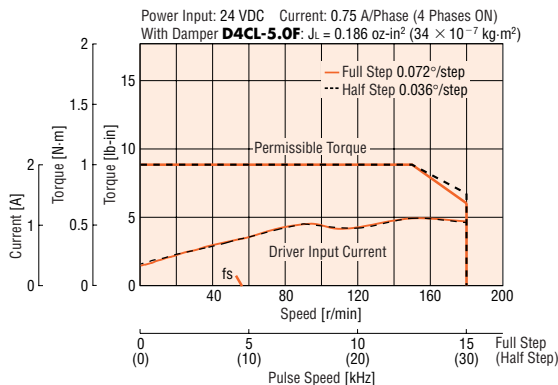

Note:

The pulse input circuit responds up to approximately 100 kHz with a pulse duty of 50%.

TH Geared Type

Motor Frame Size: □ 2.36 in. (□ 60 mm)



Specifications

Model	Single Shaft	CSK564AA-TG3.6	CSK564AA-TG7.2	CSK564AA-TG10	CSK564AA-TG20	CSK564AA-TG30
	Double Shaft	CSK564BA-TG3.6	CSK564BA-TG7.2	CSK564BA-TG10	CSK564BA-TG20	CSK564BA-TG30
Maximum Holding Torque	lb-in (N·m)	11 (1.25)	22 (2.5)	26 (3)	30 (3.5)	35 (4)
Rotor Inertia J	oz-in ² (kg·m ²)	0.96 (175×10 ⁻⁷)				
Rated Current	A/phase	1.4				
Basic Step Angle		0.2°	0.1°	0.072°	0.036°	0.024°
Gear Ratio		3.6:1	7.2:1	10:1	20:1	30:1
Permissible Torque	lb-in (N·m)	11 (1.25)	22 (2.5)	26 (3)	30 (3.5)	35 (4)
Backlash	Arc minute (degrees)	35 (0.584°)	15 (0.25°)	15 (0.25°)	10 (0.167°)	10 (0.167°)
Permissible Speed Range (Gear Output Shaft Speed)	r/min	0~500	0~250	0~180	0~90	0~60
Power Source		24 VDC±10% 2.1 A				
Excitation Mode	Full Step	0.2°/step	0.1°/step	0.072°/step	0.036°/step	0.024°/step
	Half Step	0.1°/step	0.05°/step	0.036°/step	0.018°/step	0.012°/step
Weight	Motor lb. (kg)	2.1 (0.95)				
	Driver lb. (kg)	0.31 (0.14)				
Dimension No.	Motor	5				
	Driver	6				

How to read specifications table → Page C-9

Note:

- Direction of rotation of the motor and that of the gear output shaft are the same for models with gear ratios of 3.6:1, 7.2:1 and 10:1. It is opposite for 20:1 and 30:1 gear ratios

Speed — Torque Characteristics

How to Read Speed-Torque Characteristics → Page C-10

CSK564BA-TG3.6

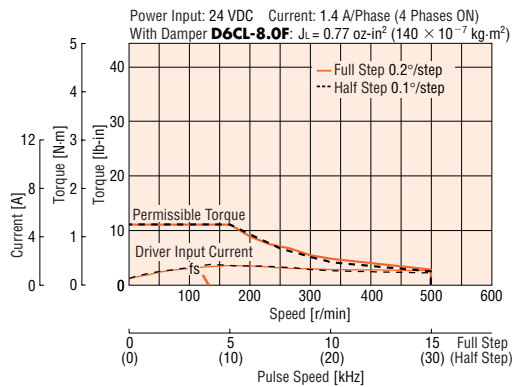

CSK564BA-TG20

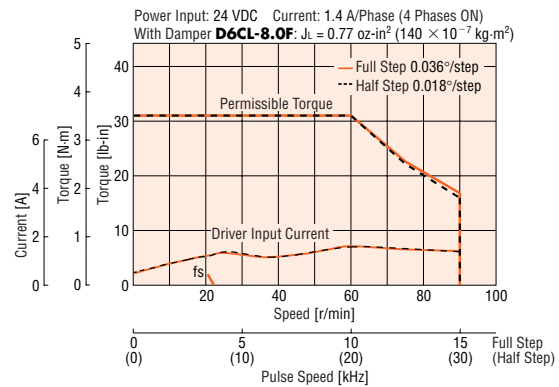

CSK564BA-TG7.2

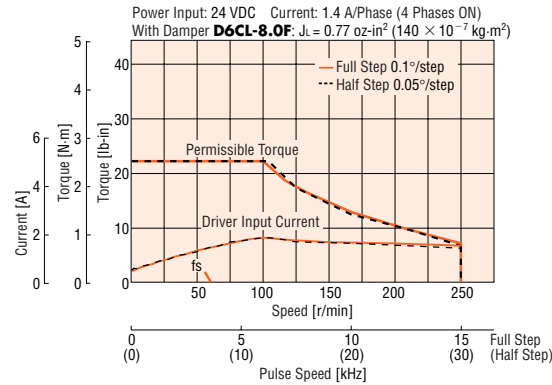

CSK564BA-TG30

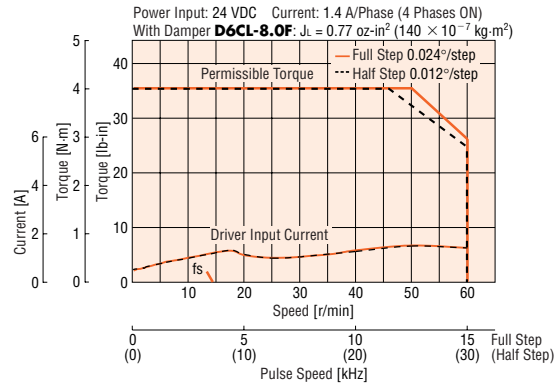

CSK564BA-TG10

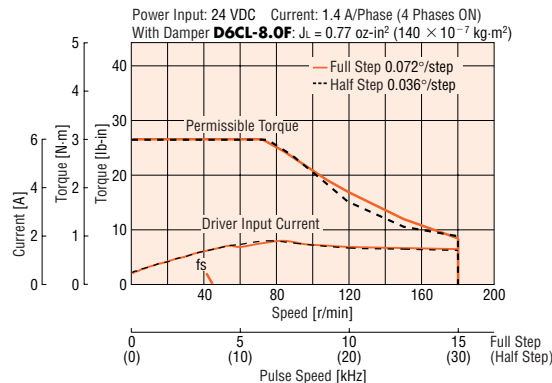

Note:

The pulse input circuit responds up to approximately 100 kHz with a pulse duty of 50%.

Common Specifications

	Input Signal Circuit	Photocoupler input, Input resistance 220 Ω, Input current 10~20 mA maximum Signal voltage Photocoupler ON: +4.5~+5 V, Photocoupler OFF: 0~+1 V (voltage between terminals)
Input Signals	● Pulse Signal (CW Pulse Signal)*	Step command pulse signal (CW step command pulse signal at 2-pulse input mode) Pulse width: 5 μs minimum, Pulse rise/fall: 2 μs maximum, pulse duty: Max. 50% Motor moves when the photocoupler state changes from ON to OFF. Maximum input frequency: 100 kHz (when a pulse duty is 50%) Negative logic pulse input.
	● Rotation Direction Signal (CCW Pulse Signal)*	Rotation direction signal Photocoupler ON: CW, Photocoupler OFF: CCW CCW step command signal at 2-pulse input mode. Pulse width: 5 μs minimum, Pulse rise/fall: 2 μs maximum. pulse duty: Max. 50% Motor moves when the photocoupler state changes from ON to OFF. Maximum input frequency: 100 kHz (when a pulse duty is 50%) Negative logic pulse input.
	● Step Angle Signal	Full Step (0.72°) at "photocoupler OFF" Half Step (0.36°) at "photocoupler ON"
	● All Windings Off Signal	When in the "photocoupler ON" state, the current to the motor is cut off and the motor shaft can be rotated manually. When in the "photocoupler OFF" state, the current level set by the RUN switch is supplied to the motor.
	● Automatic Current Cutback Release Signal	When in the "photocoupler ON" state, the "Automatic Current Cutback" function at motor standstill is disabled. When in the "photocoupler OFF" state, the "Automatic Current Cutback" function at motor standstill is activated. (Approximately 100 ms after motor stops).
Output Signals	Output Signal Circuit	Photocoupler, Open-Collector Output External use condition: 24 VDC maximum, 10 mA maximum
	● Excitation Timing Signal	The signal is output every time the excitation sequence returns to the initial stage "0". (Photocoupler: ON) Full step: signal output every 10 pulses, Half step: signal output every 20 pulses
	● Overheat Signal *	The signal is output when the internal temperature of the driver rises above approximately 194°F (90°C). (Photocoupler: ON, Automatic return) The motor current is shut off automatically if the automatic current off function is ON.
Functions		Automatic current cutback, Automatic current off,* Pulse input mode switch.*
Driver Cooling Method		Natural ventilation

* Only for CSD5828N-T (CSK59□ Package)

General Specifications

Specifications		Motor	Driver
Insulation Class		Class B [266°F (130°C)] [Recognized as Class A [221°F (105°C)] by UL and CSA standards.]	—
Insulation Resistance		100 MΩ minimum under normal temperature and humidity, when measured by a 500 VDC megger between the motor coils and the motor casing.	—
Dielectric Strength		Sufficient to withstand 1.5 kV (1 kV for CSK54 □type), 60 Hz applied between the motor coils and casing for one minute, under normal temperature and humidity.	—
Operating Environment	Ambient Temperature	14°F~122°F (−10°C~+50°C) (nonfreezing)	32°F~104°F (0°C~+40°C) (nonfreezing)
	Ambient Humidity	85% or less (non-condensing)	
	Atmosphere	No corrosive gases, dust, water or oil.	
Temperature Rise		Temperature rise of the coil measured by the Change Resistance Method is 144°F (80°C) or less. (at standstill, five phases energized)	—
Static Angle Error *1		±3 arc minute (±0.05°)	—
Shaft Runout		0.002 inch (0.05 mm) T.I.R at top of output shaft *4	—
Radial Play *2		0.001 inch (0.025 mm) max. of 1.12 lb. (5 N)	—
Axial Play *3		0.003 inch (0.075 mm) max. of 2.2 lb. (10 N)	—
Concentricity		0.003 inch (0.075 mm) T.I.R *4	—
Perpendicularity		0.003 inch (0.075 mm) T.I.R *4	—

*1 This value is for full step under no load. (The value changes with size of the load.)

*2 Radial Play: Refers to the displacement in shaft position in the radial direction, when a 1.12 lb. (5 N) load is applied in the vertical direction to the tip of the motor's shaft.

*3 Axial Play: Refers to the displacement in shaft position in the axial direction, when a 2.2 lb. (10 N) load is applied to the motor's shaft in the axial direction.

*4 T.I.R. (Total Indicator Reading): Refers to the total dial gauge reading when the measured section is rotated one revolution centered on a reference axis.

Note:

- Do not measure insulation resistance or perform the dielectric strength test while the motor and driver are connected.

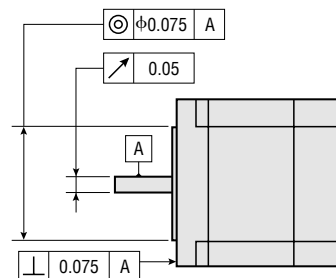

Permissible Overhung Load and Permissible Thrust Load

Unit = Upper values: lb./Lower values: N

Model	Overhung Load Distance from Shaft End [inch (mm)]					Thrust Load
	0 (0)	0.2 (5)	0.39 (10)	0.59 (15)	0.79 (20)	
CSK54□	4.5	5.6	7.6	11.7	—	The permissible thrust load [lb. (N)] shall be no greater than the motor mass.
	20	25	34	52		
CSK56□	14.1	16.8	21	29	42	
	63	75	95	130	190	
CSK59□	58	65	76	87	108	
	260	290	340	390	480	
CSK543-TG	2.2	3.1	4.5	6.7	—	3.3
	10	14	20	30	—	15
CSK564-TG	15.7	18	22	27	33	9
	70	80	100	120	150	40

Dimensions Scale 1/4, Unit = inch (mm)

Motor

Standard Type

1 Motor Frame Size: □1.65 in. (□42 mm)

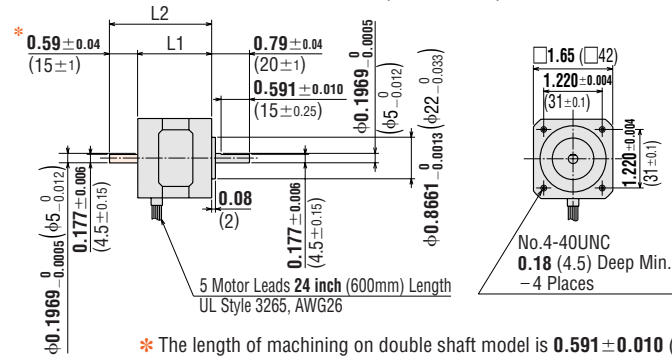

Model	Motor Model	L1 inch (mm)	L2 inch (mm)	Weight lb. (kg)	DXF
CSK543-NATA	PK543NAWA	1.3 (33)	—	0.46 (0.21)	B068U
CSK543-NBTA	PK543NBWA		1.89 (48)		
CSK544-NATA	PK544NAWA	1.54 (39)	—	0.59 (0.27)	B069U
CSK544-NBTA	PK544NBWA		2.13 (54)		
CSK545-NATA	PK545NAWA	1.85 (47)	—	0.77 (0.35)	B070U
CSK545-NBTA	PK545NBWA		2.44 (62)		

2 Motor Frame Size: □2.36 in. (□60 mm)

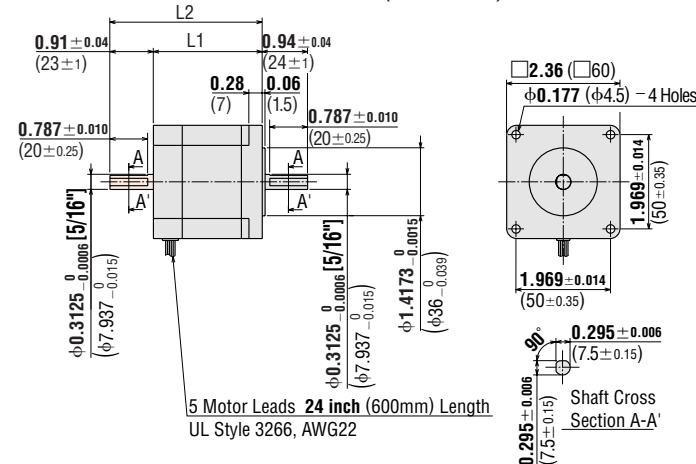

Model	Motor Model	L1 inch (mm)	L2 inch (mm)	Weight lb. (kg)	DXF
CSK564-NATA	PK564NAWA	1.83 (46.5)	—	1.3 (0.6)	B071U
CSK564-NBTA	PK564NBWA		2.74 (69.5)		
CSK566-NATA	PK566NAWA	2.26 (57.5)	—	1.8 (0.8)	B072U
CSK566-NBTA	PK566NBWA		3.17 (80.5)		
CSK569-NATA	PK569NAWA	3.43 (87)	—	2.9 (1.3)	B073U
CSK569-NBTA	PK569NBWA		4.33 (110)		

3 Motor Frame Size: □3.35 in. (□85 mm)

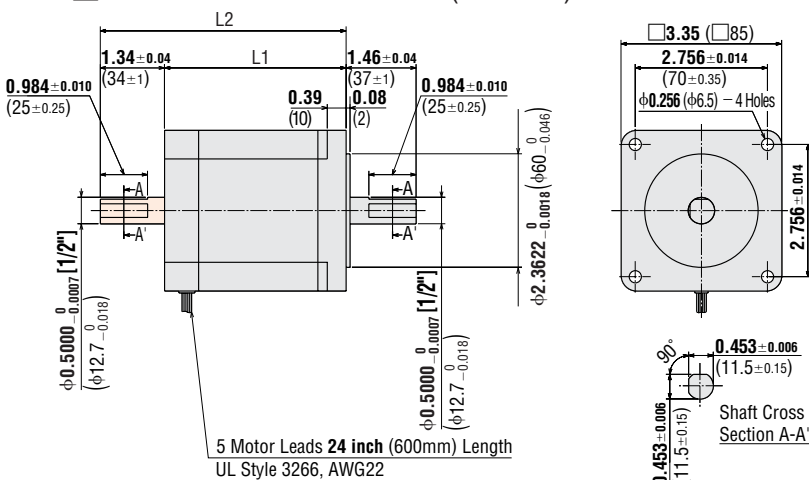

Model	Motor Model	L1 inch (mm)	L2 inch (mm)	Weight lb. (kg)	DXF
CSK596-NATA	PK596-NAA	2.6 (66)	—	3.7 (1.7)	B155U
CSK596-NBTA	PK596-NBA		3.94 (100)		
CSK599-NATA	PK599-NAA	3.78 (96)	—	6.2 (2.8)	B156U
CSK599-NBTA	PK599-NBA		5.12 (130)		
CSK5913-NATA	PK5913-NAA	4.96 (126)	—	8.4 (3.8)	B157U
CSK5913-NBTA	PK5913-NBA		6.3 (160)		

• These dimensions are for double shaft models. For single shaft models, ignore the shaded areas.

◆ TH Geared Type

4 Motor Frame Size: □1.65 in. (□42 mm)

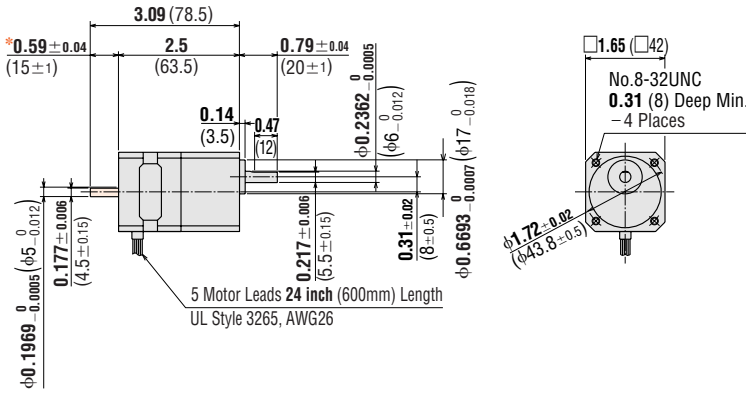

Model	Motor Model	Weight lb. (kg)	DXF
CSK543AA-TG □	PK543NAWA-T□	0.73 (0.33)	B074U
CSK543BA-TG □	PK543NBWA-T□		

- Enter the gear ratio in the box (□) within the model number.
- Screws (included)
No.8-32 UNC, 0.375 inch (9.52 mm) length, 4 pieces

* The length of machining on double shaft model is 0.591 ± 0.010 (15 ± 0.25).

5 Motor Frame Size: □2.36 in. (□60 mm)

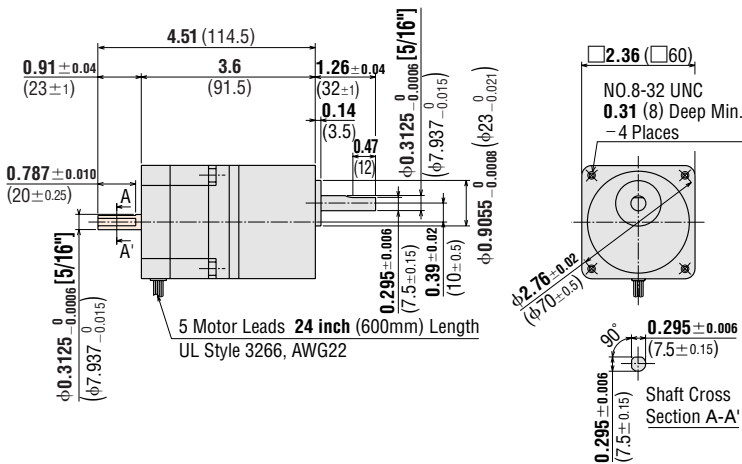

Model	Motor Model	Weight lb. (kg)	DXF
CSK564AA-TG □	PK564NAWA-T□	2.1 (0.95)	B075U
CSK564BA-TG □	PK564NBWA-T□		

- Enter the gear ratio in the box (□) within the model number.
- Screws (included)
No.8-32 UNC, 0.75 inch (19.05 mm) length, 4 pieces

• These dimensions are for double shaft models. For single shaft models, ignore the shaded areas.

● Driver

6 CSD5807N-T, CSD5814N-T

Weight: 0.31 lb. (0.14 kg) **DXF** B805U

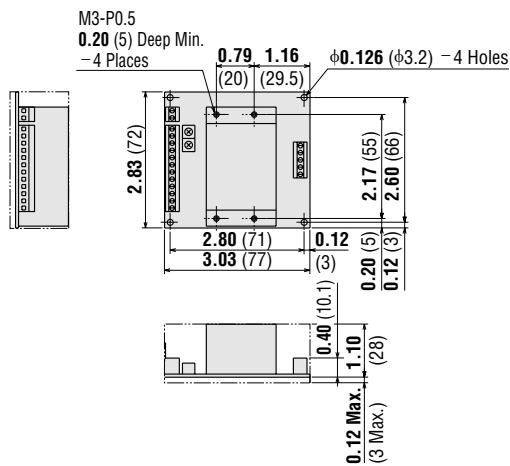

7 CSD5828N-T

Weight: 0.55 lb. (0.25 kg) **DXF** B806U

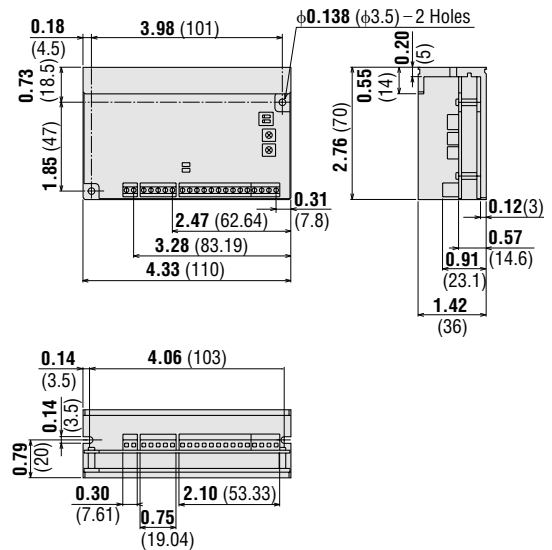

Connection and Operation

Standard Type: **CSK54**□, **CSK56**□

TH Geared Type: **CSK543**□, **CSK564**□

Standard Type: **CSK59**□

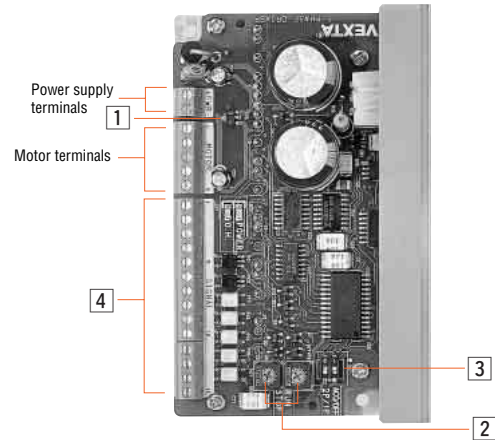
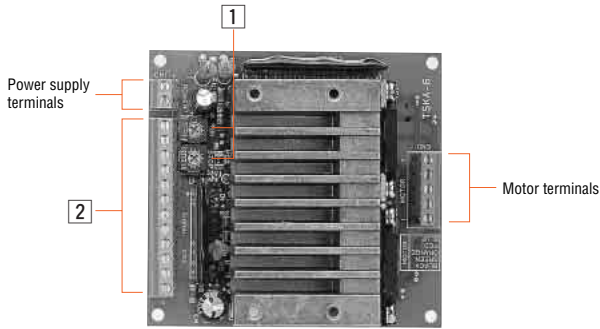

1 Current Adjustment Potentiometers

Indicator	Switch Name	Function
RUN	Motor run current potentiometer	Adjusts the motor running current
STOP	Motor stop current potentiometer	Adjusts the motor current at standstill

1 Signal Monitor Display

Indicator	Color	Function
POWER	Green	Power input display
O.H.	Red	Overheat output display

2 Input/Output Signal

Connector	Input/Output	Terminal No.	Signal Name
CN2	Input signals	1	Pulse Signal
		2	
		3	
		4	
		5	All Windings Off Signal
		6	
		7	Step Angle Select Signal
		8	
		9	Current Cutback Release Signal
		10	
	Output signals	11	Excitation Timing Signal
		12	

2 Current Adjustment Potentiometers

Indicator	Switch Name	Function
RUN	Motor run current potentiometer	Adjusts the motor running current
STOP	Motor stop current potentiometer	Adjusts the motor current at standstill

3 Function Select Switches

Indicator	Switch Name	Function
2P/1P	Pulse input mode switch	Switches between 1-pulse input and 2-pulse input
A.C.O/OFF	Automatic current off function switch	When the heat sink temperature of the driver rises above 194°F (90°C), this function automatically switches the motor current off. Function can be set and released with this switch.

4 Input/Output Signal

Connector	Input/Output	Terminal No.	Signal Name
SIGNAL	Input signals	1	Pulse Signal (CW Pulse Signal)
		2	
		3	Rotation Direction Signal (CCW Pulse Signal)
		4	
		5	All Windings Off Signal
		6	
		7	Step Angle Select Signal
		8	
		9	Current Cutback Release Signal
		10	
	Output signals	11	Excitation Timing Signal
		12	
		13	Overheat Signal
		14	

● Connection Diagrams

◆ CSK54□, CSK56□ CSK543-TG, CSK564-TG

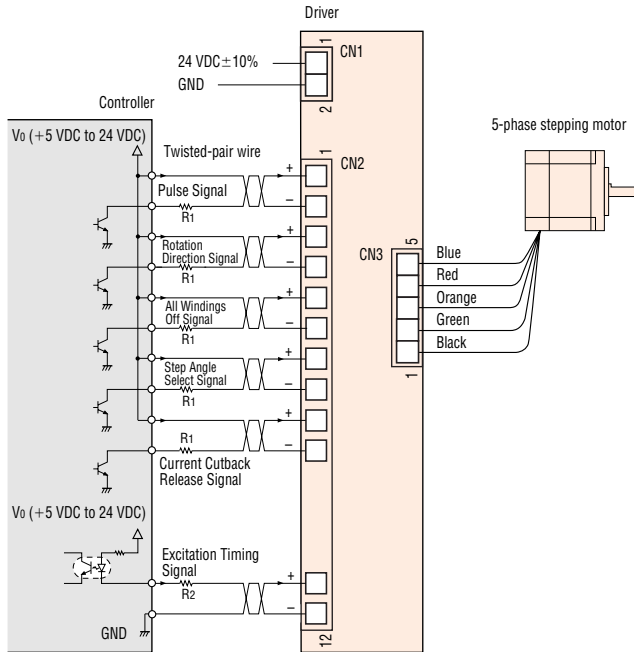

◆ Power Supply

Use an input power voltage of $24\text{ VDC} \pm 10\%$. Use a power supply that can supply sufficient input current.

Notes:

- Keep the voltage V_o between 5 VDC and 24 VDC. When V_o is equal to 5 VDC, the external resistance R_1 is not necessary. When V_o is above 5 VDC, connect R_1 to keep the current between 10 mA and 20 mA, and connect R_2 to keep the current below 10 mA.
- Use twisted-pair wire of AWG 24 or thicker and 6.6 feet (2 m) or less in length for the signal line.
- Note that as the length of the pulse signal line increases, the maximum transmission frequency decrease. (→ Technical Reference Page F-36)
- Suitable wire size for the CN1, CN2 and CN3 connector is between AWG 22 and AWG 26. Use AWG 20 or thicker for motor lines (when extended) and power supply line.
- Signal lines should be kept at least 3.9 inches (10 cm) away from power lines (power supply lines and motor lines). Do not bind the signal line and power line together.
- Use spot grounding to ground the driver and external controller.
- If noise generated by the motor lead wire causes a problem, try shielding the motor lead wires with conductive tape or wire mesh.
- Incorrect connection of DC power input will lead to driver damage. Make sure that the polarity is correct before turning the power on.

◆ Description of Input/Output Signals

Pulse Input Signal

"Pulse" signal is input to the PULSE-terminal. When the photocoupler state changes from "ON" to "OFF", the motor rotates one step. The direction of rotation is determined by the rotation direction signal.

Rotation Direction Input Signal

The "Rotation Direction" signal is input to the DIRECTION-terminal. A "photocoupler ON" signal input commands a clockwise direction rotation. A "photocoupler OFF" signal input commands a counterclockwise direction rotation.

All Windings Off Input Signal

When the "All Windings Off" (A.W. OFF) signal is in the "photocoupler ON" state, the current to the motor is cut off and motor torque is reduced to zero. The motor output shaft can then be rotated freely by hand. This signal is used when moving the motor by external force or to the manual home position.

Step Angle Select Input Signal

When the "Step Angle Select" (FULL/HALF) signal is in the "photocoupler ON" state, half step mode has been selected; when the FULL/HALF signal is in the "photocoupler OFF" state, full step mode has been selected.

Current Cutback Release Input Signal

When the "Current Cutback Release" (C.D.INH) signal is in the "photocoupler ON" state, the "Automatic Current Cutback" function is not activated.

Excitation Timing Output Signal

The Excitation Timing signal is output once each time the excitation sequence returns to step "0" in synchronization with input pulses.

The excitation sequence is designed to complete one cycle as the motor shaft rotates 7.2° . A signal is output every 10 pulses in full step mode and every 20 pulses in half step mode. (When the "Excitation Timing" signal is output, the transistor turns ON.)

◆ CSK59 □

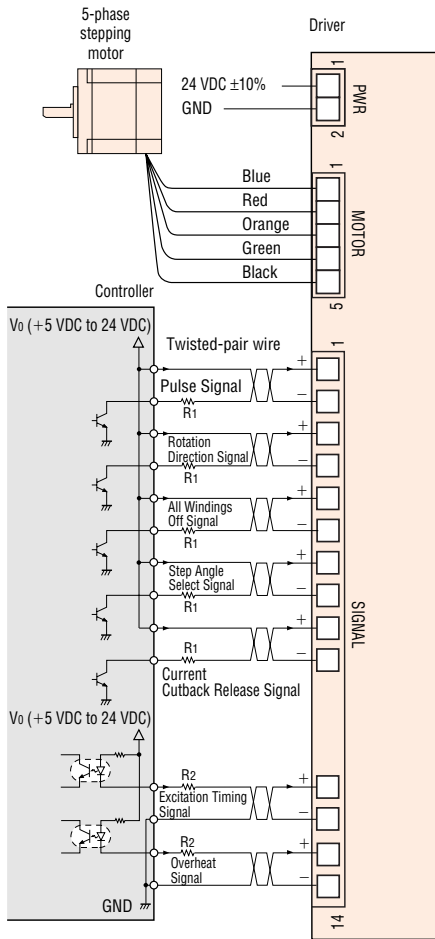

◆ Power Supply

Use an input power voltage of 24 VDC \pm 10%. Use a power supply that can supply sufficient input current.

Notes:

- Keep the voltage V_o between 5 VDC and 24 VDC. When V_o is equal to 5 VDC, the external resistance R_1 is not necessary. When V_o is above 5 VDC, connect R_1 to keep the current between 10 mA and 20 mA, and connect R_2 to keep the current below 10 mA.
- Use twisted-pair wire of AWG 24 or thicker and 6.6 feet (2 m) or less in length for the signal line.
- Note that as the length of the pulse signal line increases, the maximum transmission frequency decrease. (→ Technical Reference Page F-36)
- Suitable wire size for the "PWR", "MOTOR" and "SIGNAL" connector is between AWG 20 and AWG 26. Use AWG 20 or thicker for motor lines (when extended) and power supply line.
- Signal Lines should be kept at least 3.9 inches (10 cm) away from power lines (power supply lines and motor lines). Do not bind the signal line and power line together.
- Use spot grounding to ground the driver and external controller.
- If noise generated by the motor lead wire causes a problem, try shielding the motor lead wires with conductive tape or wire mesh.
- Incorrect connection of DC power input will lead to driver damage. Make sure that the polarity is correct before turning the power on.

◆ Description of Input/Output Signals
Pulse (CW) and Rotation Direction (CCW) Input Signal1-Pulse Input Mode
Pulse Signal

"Pulse" signal is input to the P/CW-terminal. When the photocoupler state changes from "ON" to "OFF", the motor rotates one step. The direction of rotation is determined by the rotation direction signal.

Rotation Direction Signal

The "Rotation Direction" signal is input to D./CCW-terminal. A "photocoupler ON" signal input commands a clockwise rotation. A "photocoupler OFF" signal input commands a counterclockwise direction rotation.

2-Pulse Input Mode

CW Pulse Signal

"Pulse" signal is input to the P/CW-terminal. When the photocoupler state changes from "ON" to "OFF", the motor rotates one step in the clockwise direction.

CCW Pulse Signal

"Pulse" signal is input to the D./CCW-terminal. When the photocoupler state changes from "ON" to "OFF", the motor rotates one step in the counterclockwise direction.

All Windings Off Input Signal

When the "All Windings Off" (A.W. OFF) signal is in the "photocoupler ON" state, the current to the motor is cut off and motor torque is reduced to zero. The motor output shaft can then be rotated freely by hand. This signal is used when moving the motor by external force or to the manual home position.

Step Angle Select Input Signal

When the "Step Angle Select" (FULL/HALF) signal is in the "photocoupler ON" state, half step mode has been selected; when the FULL/HALF signal is in the "photocoupler OFF" state, full step mode has been selected.

Current Cutback Release Input Signal

When the "Current Cutback Release" (C.D.INH) signal is in the "photocoupler ON" state, the "Automatic Current Cutback" function is not activated.

Excitation Timing Output Signal

The signal is output once each time the excitation sequence returns to step "0" in synchronization with input pulses.

The excitation sequence is designed to complete one cycle as the motor shaft rotates 7.2° . A signal is output every 10 pulses in full step mode and every 20 pulses in half step mode. (When the "Excitation Timing" signal is output, the transistor turns ON.)

Overheat Output Signal

The Overheat signal is output to protect the driver from heat damage if the internal temperature of the driver rises above 194°F (90°C). At the same time this signal is output, the O.H.LED on the circuit board is lit up. The O.HEAT signal is automatically turned off when the temperature of the driver heat sink falls to below 194°F (90°C). (The O.HEAT signal returns to the "photocoupler OFF" state, and O.H.LED turns off.)

Introduction

AS

AS PLUS

ASC

AS C

AS C

AS C

AS C

AS C

AS C

AS C

AS C

AS C

AS C

AS C

AS C

AS C

AS C

AS C

AS C

AS C

AS C

AS C

AS C

AS C

AS C

AS C

AS C

AS C

AS C

AS C

AS C

AS C

AS C

AS C

AS C

AS C

AS C

AS C

AS C

AS C

AS C

AS C

AS C

AS C

AS C

AS C

AS C

AS C

AS C

AS C

AS C

AS C

AS C

AS C

AS C

AS C

AS C

AS C

AS C

AS C

● Timing Chart

◆ CSK54□, CSK56□

CSK543-TG, CSK564-TG

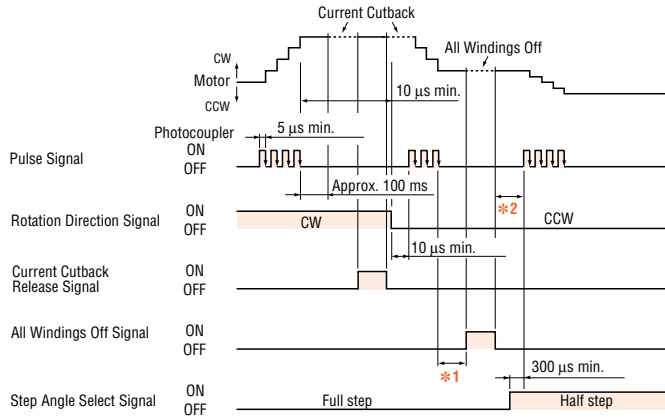

Note:

10 μs or more is the standard interval time for switching from CW to CCW. Note that the interval time varies greatly depending on the motor and load inertia.

- *1 Wait a period of time to allow the motor oscillations to end before inputting the "All Windings Off" signal. This time varies with the load inertia, the load torque and the starting pulse rate. The signal input must be stopped before the motor stops.
- *2 Never input a step pulse signal immediately after switching the "All Windings Off" signal to "photocoupler OFF" state or the motor may lose synchronism. In general, a minimum interval of 300 μs is required.

The shaded area indicates when the photocoupler is ON.

◆ CSK59□

• 1-pulse input mode

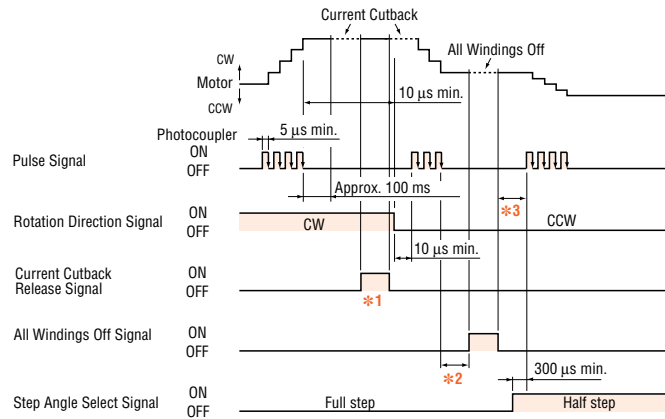

• 2-pulse input mode

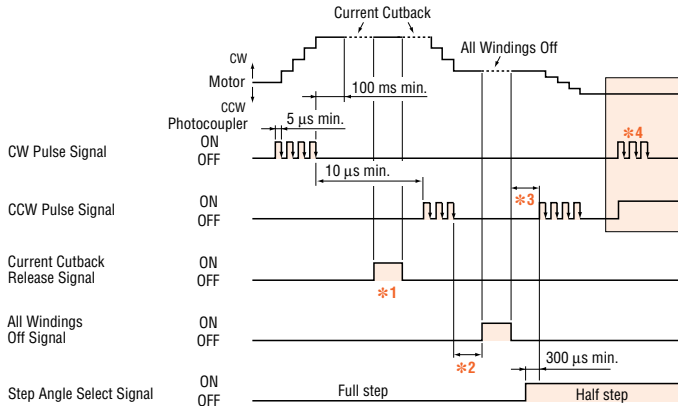

Note:

10 μs or more is the standard interval time for switching from CW to CCW. Note that the interval time varies greatly depending on the motor and load inertia.

- *1 When the signal is in the "photocoupler ON" state, the "Automatic Current Cutback" function is deactivated. Always set it in the "photocoupler OFF" state when the pulse signal is stopped.
- *2 Wait a period of time to allow the motor oscillations to end before inputting the "All Windings Off" signal. This time varies with the load inertia, the load torque and the starting pulse rate. The signal input must be stopped before the motor stops.
- *3 Never input a step pulse signal immediately after switching the "All Windings Off" signal to "photocoupler OFF" state or the motor may lose synchronism. In general, a minimum interval of 300 μs is required.

- *4 The motor will not operate properly if a pulse signal is input when either the CW or CCW input "photocoupler ON" state.

The shaded area indicates when the photocoupler is ON.

● Adjusting the Output Current

The rated output current is set at the factory. When it is necessary to change the current setting, follow the procedures described below.

◆ Connecting an Ammeter

CSK54□, CSK56□

CSK543□A-TG, CSK564□A-TG□

Connect a DC ammeter between the motor and terminal ① of CN3 connector as shown below.

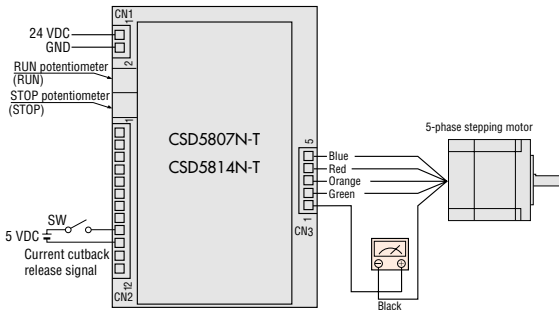

CSK59□

Connect a DC ammeter between the motor and terminal ① of the "MOTOR" connector as shown below.

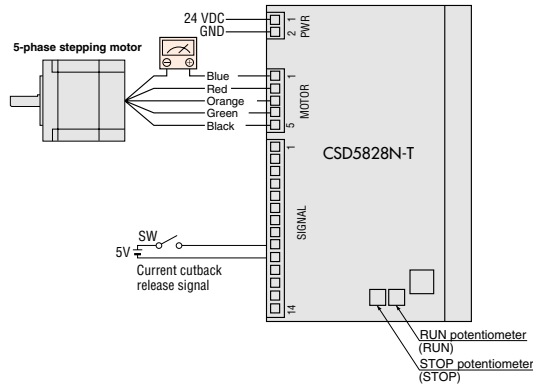

- After connecting the DC ammeter to the motor, turn on the power. (The excitation status at this point is fixed.)
- When the power is turned on, the motor enters a 4 phase excitation state, and +directional positive current flows through the **CSK54□**, **CSK56□**-black, **CSK59□**-blue motor lead wire. (Even if 4-5 phase excitation has been selected, the motor enters a 4 phase excitation state when the power is turned on. Adjust the current in this state.)
- The value measured by the ammeter represents the total current in two phases. The current for one phase is equivalent to half of the ammeter value. (When setting the current to 1.0 A/phase, adjust the current level until the ammeter reads 2.0 A.)

Notes:

- Never input pulse signals.
- Select "photocoupler OFF" for "All Windings Off" signal. (Select "photocoupler OFF" when the switch is open.)
- When the RUN current is adjusted, the current at motor standstill also changes.

◆ Adjusting the Motor Running Current

Set the "Current Cutback Release" signal to the "photocoupler ON" state (SW: ON) when adjusting the RUN current.

(1) Adjust the motor RUN current with the RUN potentiometer.

Adjusting range
 CSD5807N-T: 0.1 A/phase to 0.75 A/phase
 CSD5814N-T: 0.1 A/phase to 1.4 A/phase
 CSD5828N-T: 1.0 A/phase to 2.8 A/phase

(2) The motor operating current is set for rated current (CSD5807N-T: 0.75 A/phase, CSD5814N-T: 1.4 A/phase, CSD5828N-T: 2.8 A/phase) at the time of shipping, but it can be readjusted using the RUN potentiometer. The operating current can be lowered to suppress temperature rise in the motor/driver, or lower running current in order to allow a margin for motor torque or to reduce vibration.

Note:

- The motor RUN current should be less than the motor rated current.

◆ Adjusting the Current at Motor Standstill

Set the "Current Cutback Release" signal to the "photocoupler OFF" state (SW: OFF) when adjusting the current while the motor is stopped.

(1) Adjust the current at motor standstill with the STOP potentiometer.

Adjusting range
 CSD5807N-T: 0.1 A/phase to 0.6 A/phase
 CSD5814N-T: 0.1 A/phase to 1.05 A/phase
 CSD5828N-T: 0.7 A/phase to 2.3 A/phase

(2) At the time of shipping, the current at motor standstill is set for half the rated current. (CSD5807N-T: 0.375 A/phase, CSD5814N-T: 0.7 A/phase, CSD5828N-T: 1.4 A/phase). The STOP potentiometer can be used to readjust the current at motor standstill to the current value required to produce enough holding torque.

$$\text{Holding torque [oz-in (N·m)]} = \frac{\text{Maximum holding torque [oz-in (N·m)]} \times \text{Current at motor standstill [A]}}{\text{Motor rated current [A]}}$$

List of Motor and Driver Combinations

Type	Model	Motor Model	Driver Model
Standard	CSK543-N□TA	PK543N□WA	CSD5807N-T
	CSK544-N□TA	PK544N□WA	
	CSK545-N□TA	PK545N□WA	
	CSK564-N□TA	PK564N□WA	CSD5814N-T
	CSK566-N□TA	PK566N□WA	
	CSK569-N□TA	PK569N□WA	
	CSK596-N□TA	PK596-N□A	CSD5828N-T
CSK599-N□TA	PK599-N□A		
CSK5913-N□TA	PK5913-N□A		
TH Geared	CSK543□A-TG3.6	PK543N□WA-T3.6	CSD5807N-T
	CSK543□A-TG7.2	PK543N□WA-T7.2	
	CSK543□A-TG10	PK543N□WA-T10	
	CSK543□A-TG20	PK543N□WA-T20	
	CSK543□A-TG30	PK543N□WA-T30	
	CSK564□A-TG3.6	PK564N□WA-T3.6	CSD5814N-T
	CSK564□A-TG7.2	PK564N□WA-T7.2	
	CSK564□A-TG10	PK564N□WA-T10	
	CSK564□A-TG20	PK564N□WA-T20	
	CSK564□A-TG30	PK564N□WA-T30	

- Enter **A** (single shaft) or **B** (double shaft) in the box (□) within the model numbers.