

Orientalmotor

**NEW
PRODUCTS**

RoHS RoHS-Compliant
Motorized Linear Slides

EZ limo

EZSII Series



EZSII Series Without Electromagnetic Brake Stroke 300 mm

RoHS RoHS-Compliant

Motorized Linear Slides

EZ limo EZSII Series

The structure of this motorized linear slide has been optimized to achieve greater convenience and performance in positioning applications. The compact design facilitates easy installation and wiring into your system.



Actual Size EZS3D015-C Stroke 150 mm Without Electromagnetic Brake



Quick Positioning

The **EZSII** Series uses the α STEP stepping motor characterized by its high response and ability to eliminate missteps. By fully utilizing the performance of the α STEP, the **EZSII** Series is capable of performing quick positioning operations.

Approx. 0.19 s

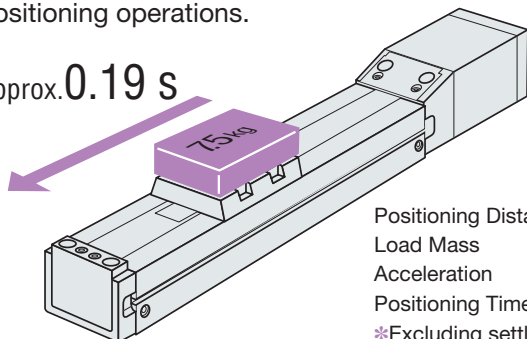

Positioning Distance 50 mm
Load Mass 7.5 kg
Acceleration 8 m/s² (0.8 G)
Positioning Time Approx. 0.19 s*
*Excluding settling time

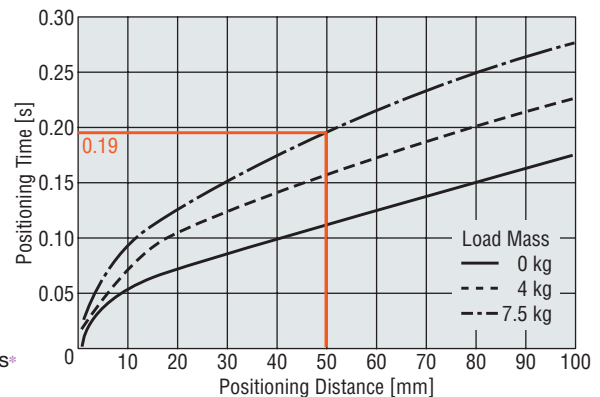

Large Transportable Mass

The **EZSII** Series can perform positioning at high speeds, supporting a large transportable mass.

●Maximum Transportable Mass: Horizontal **60** kg Vertical **30** kg
EZS6 (Lead 6 mm)

●Maximum Speed: **800** mm/s
EZS3, EZS4, EZS6

(Lead 12 mm, single-phase 100-115 VAC/200-230 VAC input)

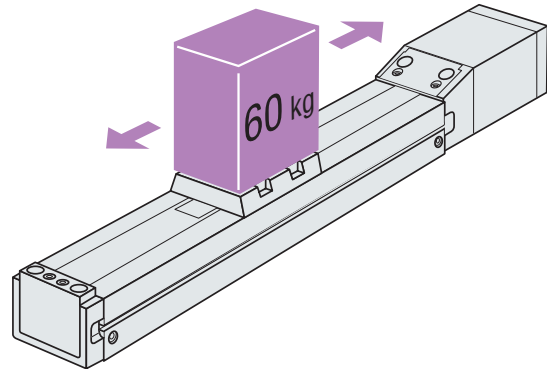

Space-Saving

The total length of linear slide is shorter for every stroke and model, which enables space-saving design of your equipment.

$$\text{Stroke} + 209.5 \text{ mm} = \text{Total length of linear slide}$$

Since the space outside the linear slide's operating range is minimized, the overall system size can be reduced.

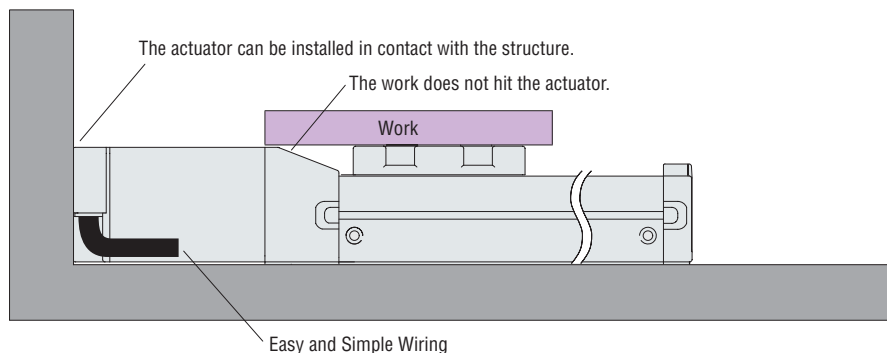

Easy to Use

Controller Key



Common Controller

A removable controller key is used that stores the parameters of various models. This means that the same controller can be used with all models and series.

Incremental Mode and Absolute Mode in One Model

One controller supports both incremental and absolute positioning functions. Specifically, the controller can be used as an absolute unit by connecting an accessory battery (sold separately).

Three Types of Controllers

The controllers are available for three power supply voltages: 24 VDC, single-phase 100-115 VAC and single-phase 200-230 VAC.

Select the controller type that suits your equipment.

RoHS-Compliant

The **EZSII** Series conforms to the RoHS Directive that prohibits the use of six chemical substances including lead and cadmium.

Actual Size **EZS3D015-C** Stroke 150 mm Without Electromagnetic Brake



Easy Stroke Selection

A desired stroke can be selected in 50 mm increments over the following ranges:

EZS3, EZS4: 50 to 700 mm

EZS6: 50 to 850 mm

Maintenance-Free for Long-Term Performance

The ball screw employs the QZ™ lubrication system, while the LM Guide® uses the Ball Retainer® to retain the coupled rolling elements. The ball screw and LM Guide® use AFF grease with reduced dust-raising property, which is designed for use in clean rooms.

Traveling Parallelism 0.03 mm

A traveling parallelism of 0.03 mm is achieved by the direct installation of the guide.

Wear Prevention

A simple roller mechanism is used to prevent the stainless sheet from wearing quickly. The roller structure suppresses dust generation caused by rubbing of the stainless sheet and the table.



Vibration Suppression Function

This newly developed control method achieves low vibration even at the speed range where large vibration occurs normally.

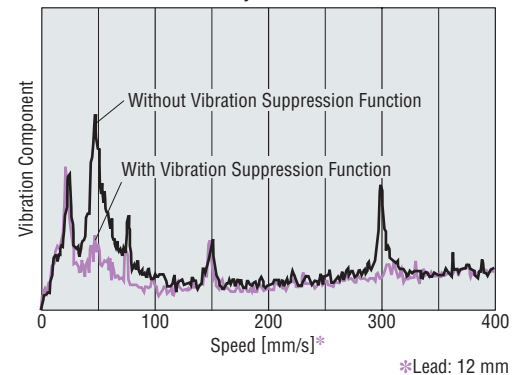

Sensorless High-Speed Return to Home Operation at Speeds up to 100 mm/s

We have developed a dedicated stop buffer to achieve the sensorless return to home operation at a maximum speed of 100 mm/s.

Once the motor detects table contact with the stop buffer, it will perform the return to home operation at 6 mm/s.



Dedicated Stop Buffer

Easy Wiring

The linear slide and controller are connected via a single cable, and the wiring distance can be extended to a maximum of 20 m*.

The cable is fitted with a connector for quick connection.

*Maximum of 10 m for 24 VDC products



The cable can be placed in a flexible conduit or cable gland with an inner diameter of $\phi 16.5$ mm.

Combining All Functions Needed to Operate a Linear Slide in Positioning Mode

This controller lets you operate all the functions required of a motorized linear slide easily.



Common Controller

A removable controller key is used that stores the parameters of various models.



Three Types of Controllers

The controllers are available for three power supply voltages: 24 VDC, single-phase 100-115 VAC and single-phase 200-230 VAC. Select the controller type that suits your equipment.

Incremental Mode/ Absolute Mode

Specifically, the controller can be used as an absolute unit by connecting an accessory battery (sold separately).



Controller Mode/ Driver Mode

The EZ limo can be combined with your existing controller to serve as a driver controlling the linear slide by pulse input.

	Controller Mode	Driver Mode*
Teaching Function	●	×
Monitoring Function	●	×
Pause Function	●	×
Area Output Function	●	×
Absolute Mode	●	●
Return to Home	●	●

*Certain functions cannot be used in the driver mode.

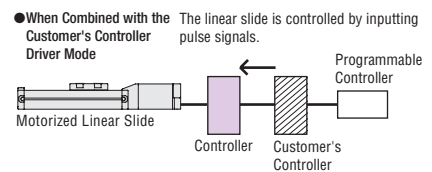
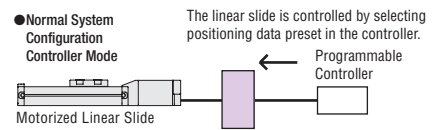

Teaching Function

Positioning data can be set in one of three methods, as specified below.

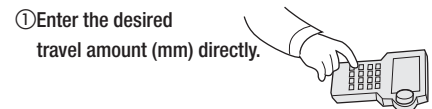

② **Direct teaching**
Move the table to the target position manually, and store the achieved position as positioning data.

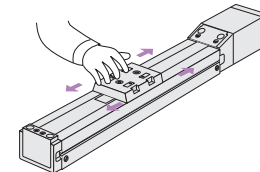

③ **Remote teaching**
Move the table to the target position using a teaching pendant or data editing software, and store the achieved position as positioning data.

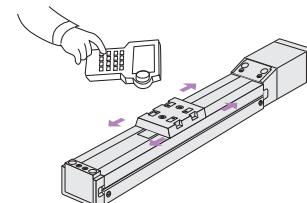

Up to 63 Points of Positioning Data

Up to 63 points of positioning data can be set in simple steps. The positioning operation can be performed in one of two ways:

●Selective positioning mode:

The set data can be selected at random.

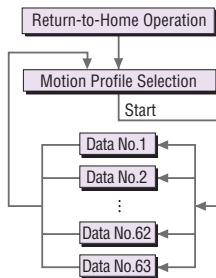

●Sequential positioning mode:

Positioning operation is performed sequentially from the desired data.

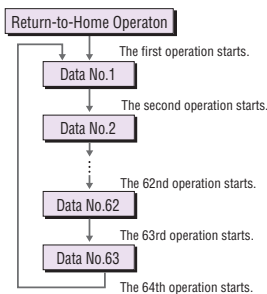

Area Output Function

A signal is output when the linear slide enters a set area arbitrarily set along the stroke. One set area can be set.

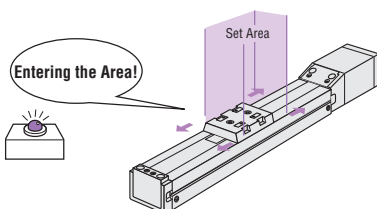
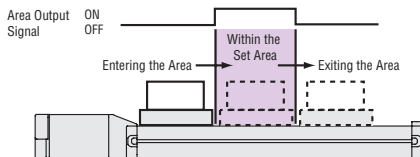

Linked Operation

Up to four operation data can be linked, thereby allowing the linear slide to change speeds without stopping.

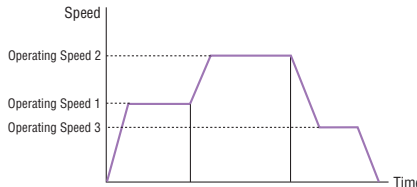

·Data with the same operation direction can be linked.

Choice of Two Return to Home Methods

●Sensorless Return to Home

Return to home is performed without the use of home sensors.

The home position and return to home speed (maximum of 100 mm/s) can be adjusted, and the direction of return to home can also be changed.

●Return to Home Using Sensors

Return to home is performed using home sensors.

Sensors are sold separately as accessories*.

(*Refer to page 40 for the sensor set.)

Output of Current Position and Error Code

The current position, error code and other data can be output to an external device.

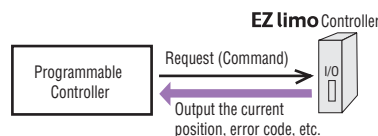

Extensive Adjustment Functions

●Acceleration

Four patterns of acceleration/deceleration setting are possible according to your operating conditions. Acceleration and deceleration can be set separately.

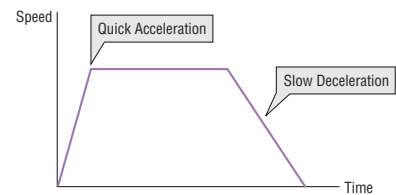

●Speed Filter

Use this filter to suppress shocks at starting and stopping or to reduce vibration during low-speed operation. With the speed filter function you can control the motor to minimize speed fluctuations even when switching the speed rapidly between operation commands.

The set value can be adjusted digitally (over a range of 1 to 100). Increasing the set value makes the movement smoother while decreasing the synchronism with the command.

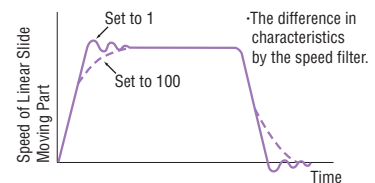

Easy Editing of Positioning Data

A teaching pendant and data editing software are available.

Choose the appropriate accessory based on the required functions.



Teaching Pendant (sold separately)
Model: **EZT1**



- All functions required for operation and adjustment, including setting of positioning data, test operation, and I/O monitoring, are provided.
- The dialogue-type user interface ensures easy operation. All you need is to enter values in the necessary fields.
- No dedicated power supply is necessary. Simply connect the cable to the controller.

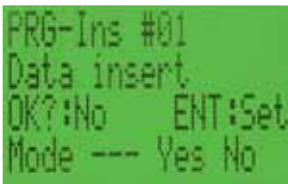

Functions of Teaching Pendant (**EZT1**) and Data Editing Software (**EZED2**)

The table below summarizes the functions available with the teaching pendant (**EZT1**) and data editing software (**EZED2**).

Choose the appropriate tool based on the required functions.

Function	Item	
	Teaching Pendant (Model: EZT1)	Data Editing Software (Model: EZED2)
Cable Length	5 m	5 m ^{*1}
Display	LCD 17 characters × 4 lines	PC screen
Emergency Stop Switch	○	×
Operation Data Setting	○	○
Parameter Setting	○	○
Teaching Function (Direct/Remote)	○	○
Operation Data Monitoring	○	○
I/O & Alarm History Monitoring	○	○
Waveform Monitoring	×	○
Test Operation	○	○
Data Copy	×	○
Printing Function	×	○ ^{*2}

○ : Available × : Not available

*1 PC interface cable (supplied) is used.

*2 The printing function is not available on computers running Windows® 98/Me.

Data Editing Software (sold separately)
Model: **EZED2**



- All functions required for operation and adjustment, including setting of positioning data, test operation, and I/O monitoring, are provided.
- Running on any Windows based computer[®], the software is a graphic navigation tool that guides you through various operations in easy steps. This user-friendly feature makes this an ideal accessory for editing large volumes of data.
 - * Refer to page 39
- You can also access waveform monitoring, data copy and other features not available on the teaching pendant.

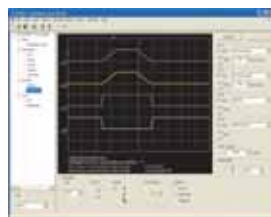

Selection of Motorized Linear Slides EZSII Series

Linear Slide Size		EZS3				EZS4				EZS6			
Linear Slide Width × Height		54 mm × 50 mm				74 mm × 50 mm				74 mm × 66.5 mm			
Screw Type		Rolled Ball Screw											
Power Supply Voltage		24 VDC		Single-Phase 100-115 VAC/ Single-Phase 200-230 VAC		24 VDC		Single-Phase 100-115 VAC/ Single-Phase 200-230 VAC		24 VDC		Single-Phase 100-115 VAC/ Single-Phase 200-230 VAC	
Lead [mm]		12	6	12	6	12	6	12	6	12	6	12	6
Maximum Load Moment [N·m]	M _P	4.2				8				45.7			
	M _Y	4.2				8				37.5			
	M _R	10.5				27.8				55.6			
Maximum Transportable Mass in Horizontal Direction [kg]	60												
	50												
	40												
	30												
Maximum Transportable Mass in Vertical Direction [kg]	30												
	25												
	20												
	15												
Maximum Speed [mm/s]	800												
	700												
	600												
	500												
Repetitive Positioning Accuracy [mm]	±0.02												
	Stroke [mm]												
Available in 50 mm increments	800												
	700												
Electromagnetic Brake	50												
	700												

Maximum Transportable Mass in Horizontal Direction [kg]	7.5	15	7.5	15	15	30	15	30	30	60	30	60
Maximum Transportable Mass in Vertical Direction [kg]	3.5	7	3.5	7	7	14	7	14	15	30	15	30
Maximum Speed [mm/s]	600	300	800	400	600	300	800	400	600	300	800	400
Stroke [mm]	50	50	50	50	50	50	50	50	50	850	850	850

With electromagnetic brake and without electromagnetic brake versions are available

Overview
Selection
System Configuration
Product Line
Specifications
Connection and Operations
Accessories
Selection Calculations